

# ADL150 DOWNLIGHT

## LED RECESSED DOWNLIGHT



- Philips Fortimo or Xicato XTM technology
- Standard CRI 83+ or Artist high CRI 98 version
- 3000K or 4000K
- High quality, mirror finish low glare reflector
- Excellent colour consistency from luminaire to luminaire (Xicato)
- 5 year colour consistency warranty - no colour shift (xicato)
- Thin 2.5mm white polycarbonate trim
- Made in Australia
- L70B0 at 55,000 hours (Xicato)
- L70B10 at 50,000 hours (Fortimo)
- Available in a Bluetooth dimmable version refer to Smart Lighting Catalogue

### PHILIPS FORTIMO – 83+ CRI

Non Dimmable	DALI Dimmable	Beam	CCT	Lumens	Watts
ADL150.1100.61.3000	ADL150.1100.66.3000	60°	3000K	882	11.5
ADL150.2000.61.3000	ADL150.2000.66.3000	60°	3000K	1489	20.5
ADL150.3000.61.3000	ADL150.3000.66.3000	60°	3000K	2232	29
ADL150.1100.61.4000	ADL150.1100.66.4000	60°	4000K	882	10.5
ADL150.2000.61.4000	ADL150.2000.66.4000	60°	4000K	1489	18.6
ADL150.3000.61.4000	ADL150.3000.66.4000	60°	4000K	2232	27

### XTM 240V – 83+ CRI

Non Dimmable	DALI Dimmable	Beam	CCT	Lumens	Watts
ADL150.XTM7.8030.61	ADL150.XTM7.8030.66	55°	3000K	2080	23
ADL150.XTM7.8040.61	ADL150.XTM7.8040.66	55°	4000K	2080	23
ADL150.XTM10.8030.61	ADL150.XTM10.8030.66	55°	3000K	2960	34
ADL150.XTM10.8040.61	ADL150.XTM10.8040.66	55°	4000K	2960	34
ADL150.XTM14.8030.61	ADL150.XTM14.8030.66	55°	3000K	3868	47
ADL150.XTM14.8040.61	ADL150.XTM14.8040.66	55°	4000K	3868	47

### XTM 240V 98 CRI

Non Dimmable	DALI Dimmable	Beam	CCT	Lumens	Watts
ADL150.XTM7.9530.61	ADL150.XTM7.9530.66	55°	3000K	1640	23
ADL150.XTM7.9540.61	ADL150.XTM7.9540.66	55°	4000K	1640	23
ADL150.XTM10.9530.61	ADL150.XTM10.9530.66	55°	3000K	2300	34
ADL150.XTM10.9540.61	ADL150.XTM10.9540.66	55°	4000K	2300	34

### PHOTOMETRICS

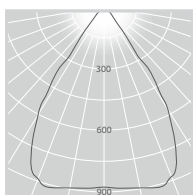

ADL150.1100.61.3000

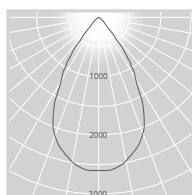

ADL150.3000.61.4000

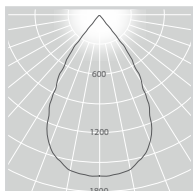

ADL150.2000.61.3000

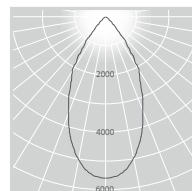

ADL150.XTM14.8030.61

## COLOUR FINISH



## OPTIONAL ACCESSORIES

Frosted glass inlay IP44\*\*  
Order code - SDL150-G4



Vandal resistant lens  
Order code - SDL150-VR



Clear glass inlay IP44\*\*  
Order code - SDL150-G5



\*\*IP Rating is from below the ceiling only

## DIMENSIONS - XTM

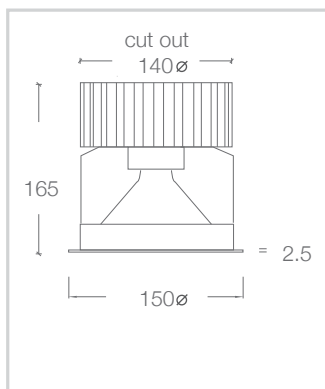

## DIMENSIONS - FORTIMO

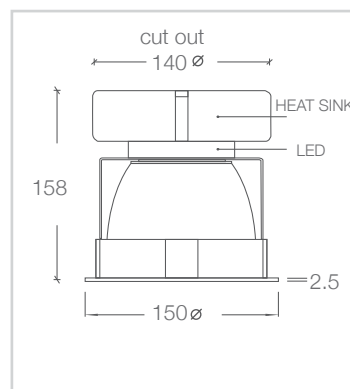

**Street Address:**  
39 Tinning Street, Brunswick,  
Victoria, 3056, Australia

**Postal Address:**  
PO BOX 5084  
Moreland West VIC 3055

T +61 3 9222 5522  
[www.elslighting.com.au](http://www.elslighting.com.au)

